



EVACUATOR FOR SCRAPS OR SHORN PIECES

“SLIM mod.1”

Applied Force of Inertia

Users Manual

Characteristics – Maintenance – Spare parts

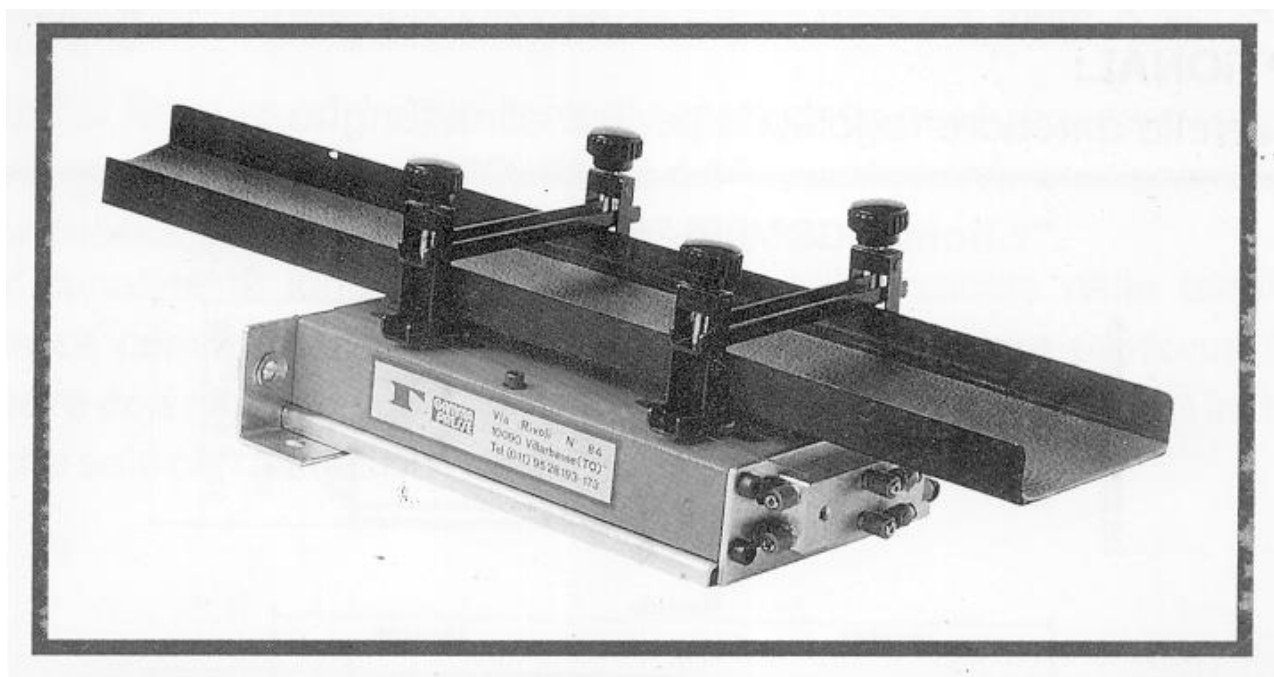

OPERATING CONCEPT

The force of inertia created by “**SLIM**” creates a horizontal motion on the raceway to translate scraps or shorn pieces.

The pneumatic operation of “**SLIM**” ensures operating safety and easy installation.

The interchangeable raceways, due to their simplicity, can also be built by the user.

GAMMA PRESSE offers its customers standard raceways, even in the oil-proof version, always in stock.

Standard raceway measurements		
Length	Width	Height
500 mm	50 mm	25 mm
500 mm	100 mm	25 mm
800 mm	50 mm	25 mm
800 mm	100 mm	25 mm
Other measurements upon request		

“SLIM” is supplied complete with:

- Vibrating body;
- Cyclical valve complete with F.R.L. assembly and fastening semi-collars;
- Rilsan pipe (3 m long, 4 mm Ø);
- Standard raceway (not oil-proof) of your choice.

(The raceways are all supplied with a deadening slab).

For proper operation, we suggest that the user carefully follow these few, but important, instructions in this manual.

INSTALLATION

Fix the F.R.L. unit and connect it to the compressed air supply by means of an ON-OFF tap. Fill the oil cup with lubricant for pneumatic circuits and regulate the quantity of drops (one drop every 2 hours approx.).

We recommend: AGIP OTE45 – FIAT HTE46 – MOBIL DTE 26

IT IS RECOMMENDED to never unscrew the cups of the F.R.L. assembly while there is pressure inside.

Regulate the pressure to 4 bar max.

To vary the frequency, adjust the regulator located on the cyclical valve (fig. 1). We recommend 120 impulses a minute.

IMPORTANT! When regulating, avoid violent impacts on the limit switches of “**SLIM**” (these impacts may cause low scans). **DO NOT** tamper with the flow regulators located on the calibrated drains and sealed by Gamma Presse. Any tampering will nullify all warranties.

INVERSION of sliding direction.

- By connecting the tubes in A with A and in B with B (fig. 1 and 2), you will obtain front sliding (fig. 3);
- By connecting tubes in B with A and in A with B (fig. 1 and 2), you will obtain rear sliding (fig. 4).

POSITIONING or changing raceway

- Loosen fastening knobs and slide into the desired position. Same procedure for replacing (fig. 2);
- Remember to close fastening knobs tightly.

Oil-proof raceway (where fitted)

- The oil-proof raceway (to be requested when there are very oily scraps or oil dripping in the raceway) must be mounted with the spiking in the sliding direction (fig. 5).

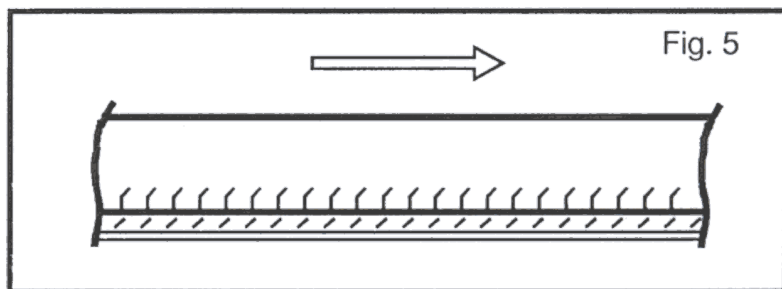
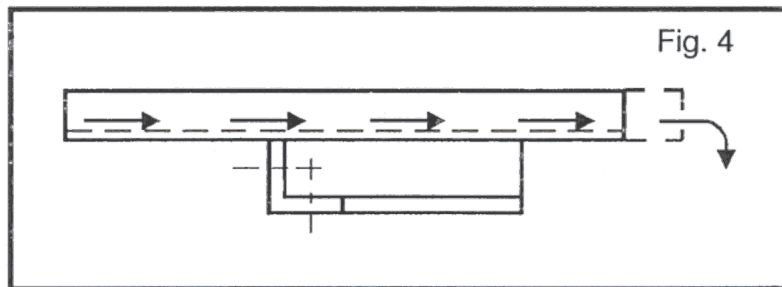
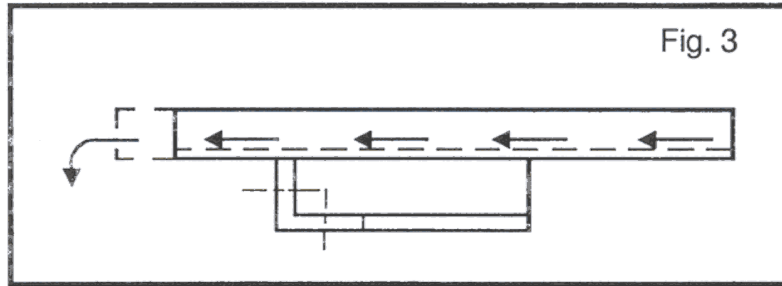
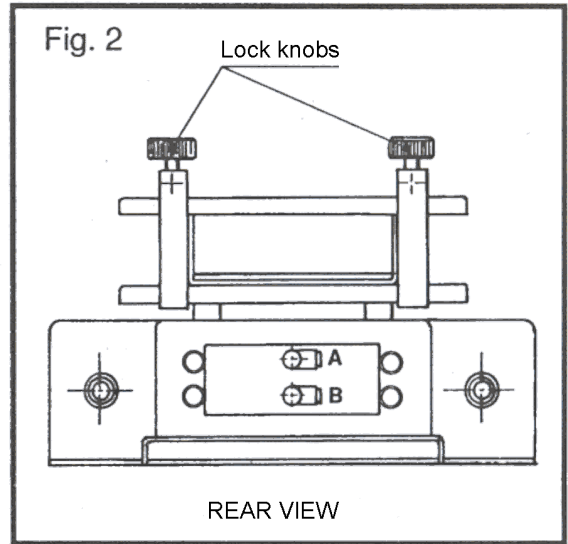
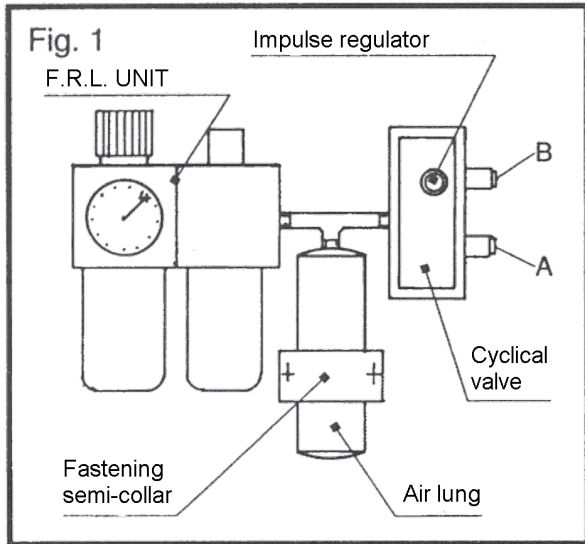

RACEWAYS for special needs

The user can easily build the raceways and regulate them forward and reverse according to his own needs.

- Minimum **PASSAGE** of raceway:
- Width = W raceway + 2 mm
- Height = H raceway + 2 mm

EXAMPLE:

A raceway that is 100 mm wide and 25 mm high requires a usable port of at least 102 x 27.

Spare deadening **SLABS**

If spare slabs are needed, our deadening slabs are available in the standard dimensions, with double adhesive coating, ready to be fixed.

Or in sizes from 1 m x 0.5 m, without two-sided adhesive coating.

OVERALL DIMENSIONS and distance between points for the fastening of "SLIM" (see fig. 6.)

It is recommended to fix the apparatus to an adequately solid support or base.

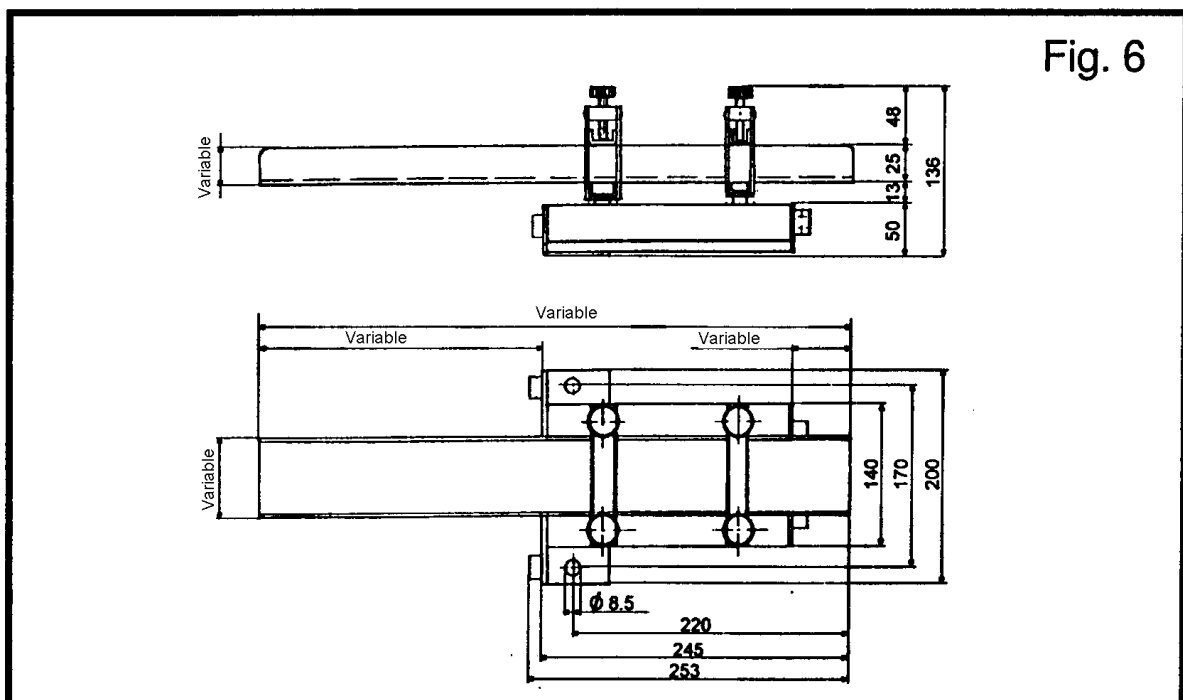

SOME POSSIBILITIES FOR FASTENING

- to base (fig. 7)
- to front panel (fig. 8)
- to base upside-down (fig. 9)
- to front panel upside-down (fig. 10)

EXAMPLES OF APPLICATION

- Double and staggered raceway (fig. 11)
- Inclined raceway (fig. 12)

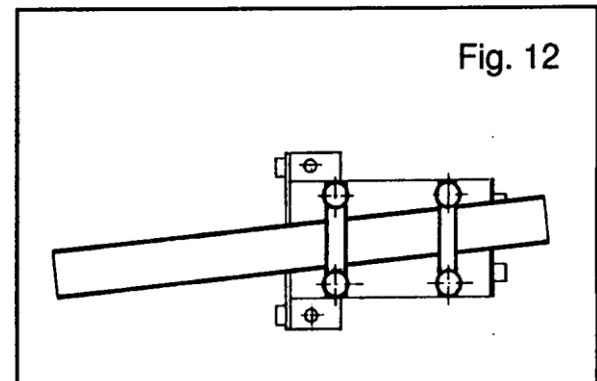
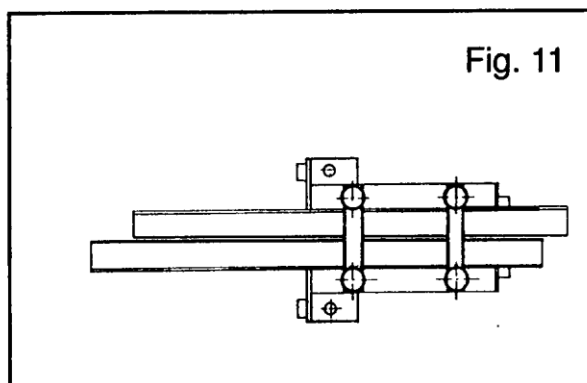
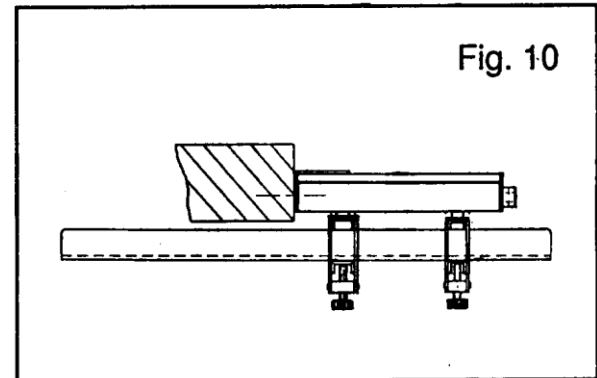
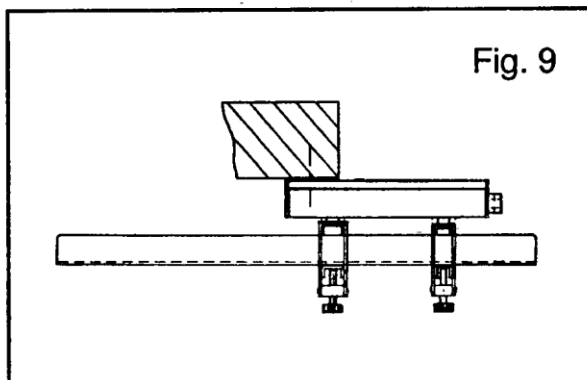
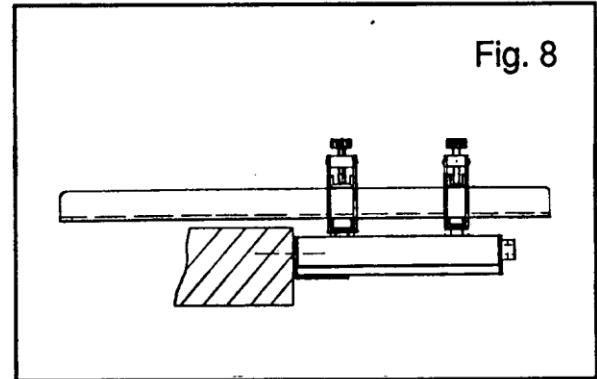
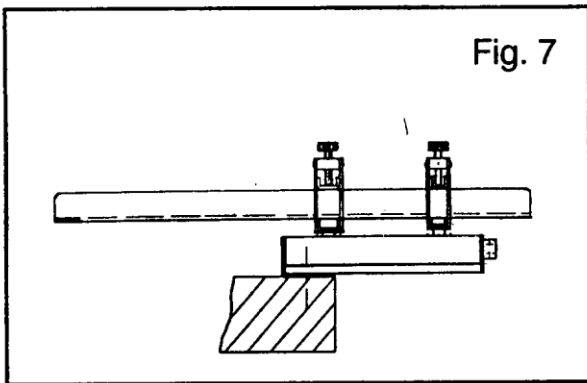
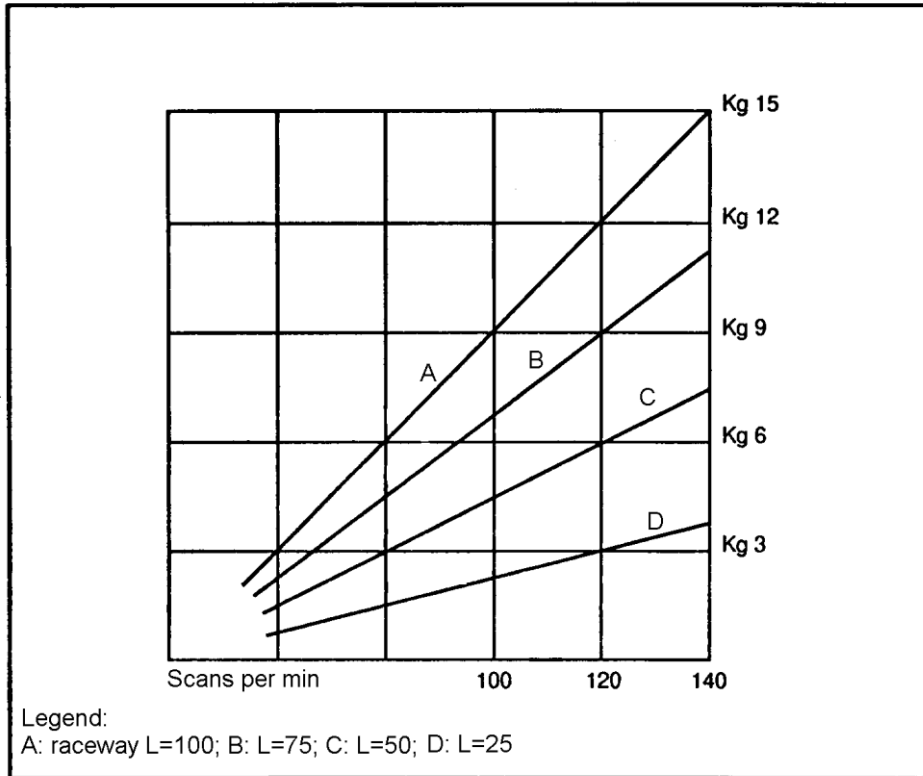

DIAGRAM OF EVACUATION CAPACITY IN Kg/min

Data refers to oily scraps of different shapes and sizes, with pressure at 4 bar



AIR CONSUMPTION TABLE (expressed in liters)

	Scans per min	Consumption l/min
4 Bar	140	15,8
	130	14,7
	120	13,5
	110	12,4
	100	11,3
3,5 Bar	140	13,8
	130	12,8
	120	11,8
	110	10,8
	100	9,8
3 Bar	140	11,8
	130	11,0
	120	10,1
	110	9,3
	100	8,5

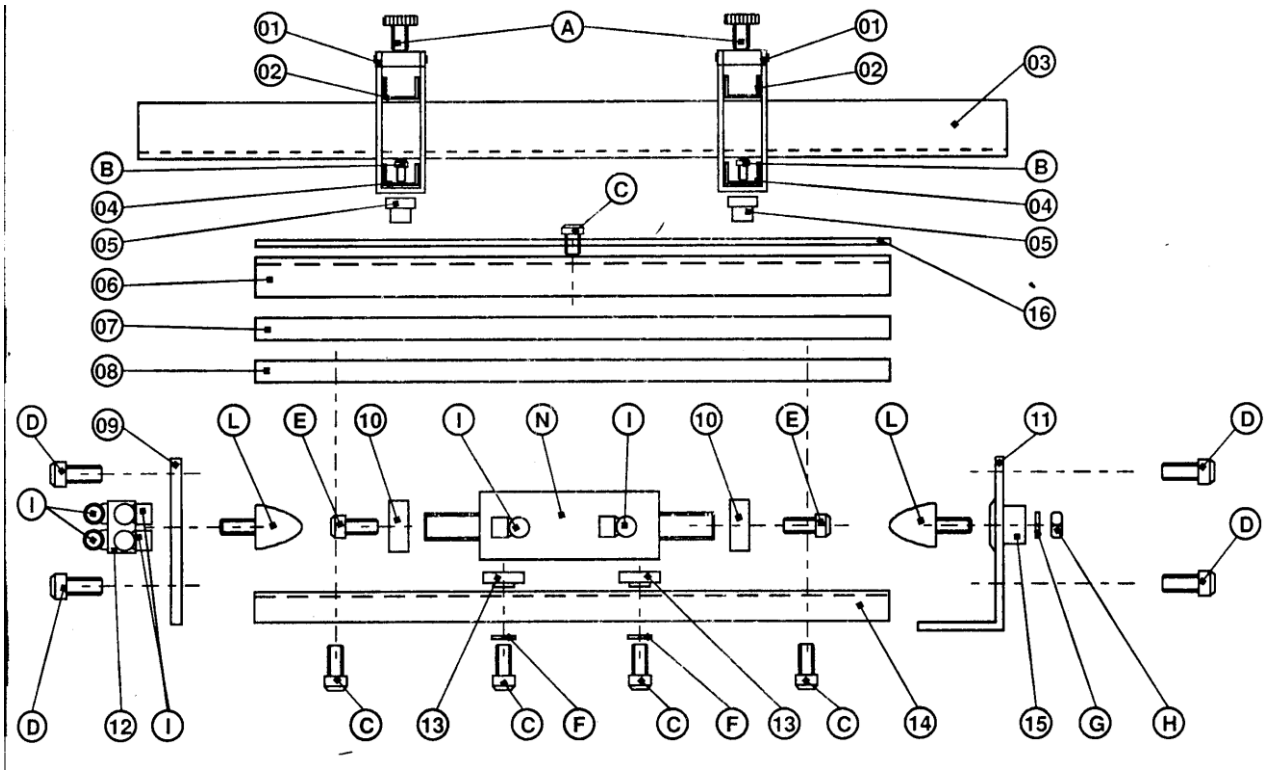

LEGEND

01	Locking unit	A	Knob
02	Upper bracket	B	Screws
03	Raceway	C	Screws
04	Lower bracket	D	Screws
05	Spacer	E	Screws
06	Lid	F	Grover Ø 5
07	Upper push rod	G	Grover Ø 5
08	Lower push rod	H	Nut
09	Upper head	I	Rotating union
10	Head plate	L	Bumper
11	Front head	M	Stem cylinder 20 x 40 Pan 323
12	Distribution frame		
13	Cylindrical clamp nut		
14	Base		
15	Bush		
16	Guard		

Gamma Presse reserves the faculty to change the characteristics of its products without notice, for the purpose of improving the quality.

GAMMA PRESSE'S PRODUCT

GAMMA SYSTEM s.r.l. – 10044 PIANEZZA (TO) – Via Torino, 24/I – Tel. +39.011.968.24.66 r.a. – Fax +39.011.967.42.11 – e-mail: info@gammasystem.com
 Capitale Sociale € 10.400 i.v. – REA 553355 – R.I. n° 4121/81 – Codice Fiscale e Partita IVA 02363550019